

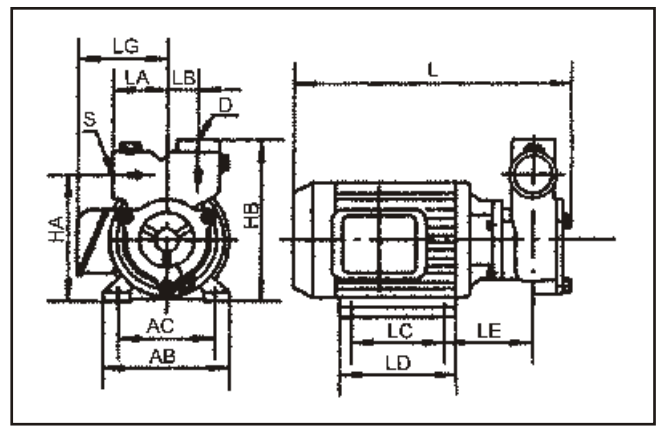

**QY**

**WORKING CONDITIONS**

- | Extra-thin clean, low-viscous liquid, or liquid containing extra-fine foreign matters
- | Liquid temperature:-15°C~+120°C
- | Maximum ambient temperature:+40°C
- | Gas-liquid ratio:1:9(gas suction volume 8-10%)
- | Inlet:horizontal, Outlet:Vertical

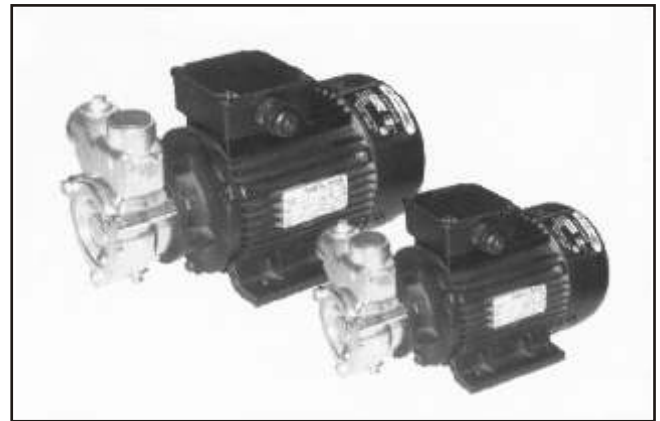

**Installation dimension**

Model	HA	HB	AB	AC	LD	LC	L	LG	LA	LB	LE	S	D
20QY- 1	128	158	150	110	120	90	320	130	55	20	100	¾"	½"
25QY- 2	150	185	165	125	130	100	327	146	60	28	105	1"	¾"
40QY- 6	185	230	200	160	180	140	444	160	70	40	135	1½"	1¼"
50QY- 12	232	290	280	216	200	140	570	210	77	47	190	2"	1½"

**Performance table**

Model	(kw)	H (m)	10	20	30	40	50	60	70
20QY- 1	0.55	Q (m³/h)	2.8	2.2	1.6	1	0.4		
25QY- 2	1.1		3.5	2.8	2.5	2	1.6	1	
40QY- 6	3		8	7.5	6.5	6	5.5	4.5	3.5
50QY- 12	5.5		18	16	15	14	12	10	7.5

